

P.C.B LAYOUT MOUNTING PATTERN



SPECIFICATIONS

1.MATERIAL:

- a.INSULATOR: PA9T; Color: BLACK
- b.CONTACT: PHOSPHOR BRONZE
- c.BRASS/SHEEL: BRASS

2.PLATING :

- a.CONTACT:
 - Au PLATING ON THE CONTACT AREA: GOLD FLASH
 - TIN PLATING ON THE SOLDER AREA;
 - NICKEL UNDERPLATING OVERALL;
- b.BRASS/SHELL: NICKEL PLATING OVERALL;

3.ELECTRICAL:

- a.DIELECTRIC WITHSTANDING VOLTAGE: AC 500V
- b.CONTACT RESISTANCE: 30mΩ Max.
- c.INSULATION RESISTANCE: DC 250V / 1,000MΩ MIN;
- d.CONTACT CURRENT RATING: 1Amp. 30V AC;
- e.OPERATING TEMPERATURE: -55°C~ 85°C

4.MECHANICAL:

- a.INSERTION FORCE: 3.57Kg MAX;
- b.WITHDRAWAL FORCE: 1.02Kg MIN;

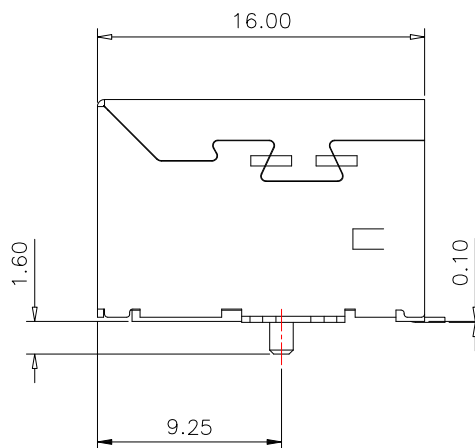
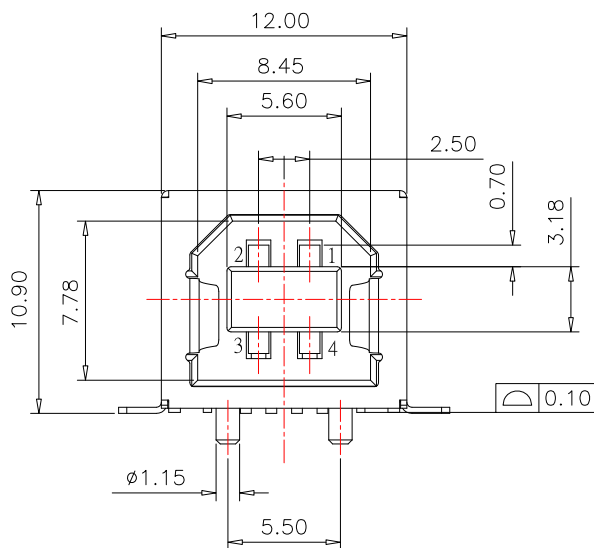

TOLERANCE UNLESS OTHERWISE STATED:

Up to 5 ±0.2
 Above 5 ~ 15 ±0.3
 Above 15 ~ 30 ±0.4
 Above 30 ~ 50 ±0.5
 Angle ±0.3°

3RD. ANGEL'S



UNITS MM

DRAWN BY: Frank Wu
 CHECKED BY: Jacky Chen
 APPROVED BY: Tony Kao

DATE: 02/06/12
 DATE: 02/06/12
 DATE: 02/06/12

MAT'L		TITLE	CONNECTOR
FINISH		MODLE	USB BF SMD TYPE
SCALE	1 : 1	DWG NO.	SUB-110S-B-S165
SHEET NO.	1 of 1	PART NO.	SUB-110S-B-S165

SIZE	A4
VER	B

ITEM NO.	DESCRIPTION	DRAWN	DATE